

# DP800 Injection Pump

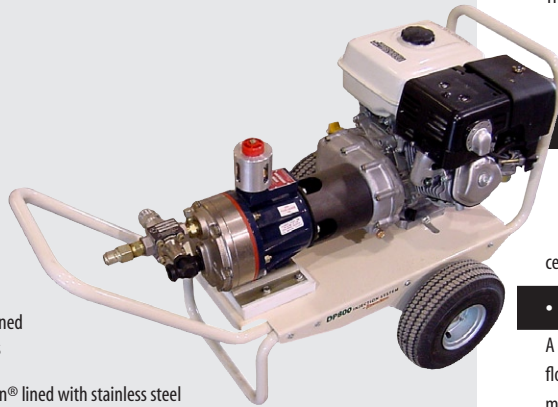

## Pump Harsh Remediation Compounds With DP800 Injection Pump

- Mobile ... Compact
- Few Replaceable Parts
- High volume ... 8 gpm
- Outlet pressure ... 650 psi
- Operates Independently of Probe Machine
- Use Without Vehicle Nearby
- Optional suction hose designed to withstand harsh oxidants
- Optional outlet hose is Teflon® lined with stainless steel jacket to withstand oxidants.
- Capable of "bottom up" or "top down" injections
- Self-priming pump
- Internal components of pump resistant to harsh oxidants, such as permanganates
- All mechanical operation – no electronics on board.



DP800 Specifications	
Weight.....	182 lb .....83 kg
Pump Type.....	Shaft-driven triple diaphragm pump
Power Source Engine.....	Honda Model GX270
Engine Fuel Capacity.....	1.59 gal .....6.0 L
Engine Horsepower.....	9.0 Hp gasoline
Pump Displacement.....	.00046 gal/rev .....0.17 L/rev
Pump Oil Capacity.....	1.1 qts ..... 1.05 L
Pressure Rating (max).....	650 psi.....45 bar

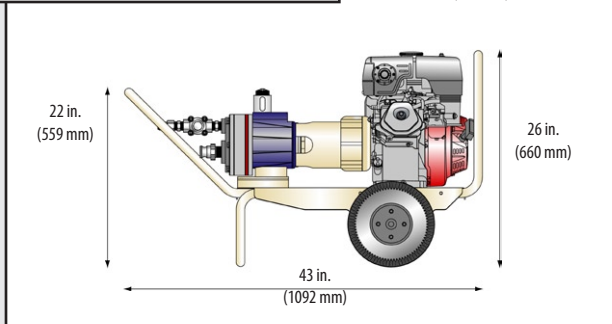
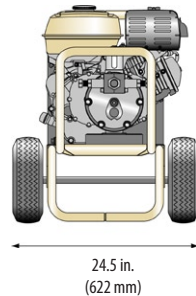

### • What is this pump used for?

The DP800 was designed to pump chemicals that are injected in high volumes where low volume/high pressure pumps are not well suited. At 8 gpm, the DP800 can pump most chemicals 2-3 times faster than the Geoprobe® GS series machines.

### • What should I NOT pump with this machine?

ORC®, Bentonite Grout, HRC®, Cement, or any material that has the ability to set up in a hardened state when dehydrated or dried. Materials such as HRC® or molasses should not be pumped due to their high viscosity, nor should ORC® and cement-based grouts due to their tendency to harden inside the pump.

### • How do I deliver material to the pump?

A gravity-fed supply is recommended, especially when operating the pump at high flow rates. The DP800 has the ability to prime itself, and it is capable of drawing material out of a 55-gallon drum as well. The pump is supplied with a 1.0 in. PVC hose assembly.

### How does the pump operate?

The pump is driven by a 9HP Honda engine with 2:1 gear reduction and centrifugal clutch. The pump will operate at most engine speeds.

### How much time is required for cleanup?

Cleanup is fairly straightforward. After pumping is complete, simply allow clean water to run through the pump at high speed for several minutes. This flushes any residual chemicals or materials out of the pump.

### How much maintenance does the DP800 require?

The DP800 is a fairly low maintenance pump. The Honda engine requires 1 quart of 30-wt motor oil. The gear reduction case requires approximately 1/3 to 1/2 quart of 30 wt engine oil. The diaphragm pump unit, which requires 1.1 quart of 30-wt. engine oil, is equipped with Viton diaphragms that wear very well.

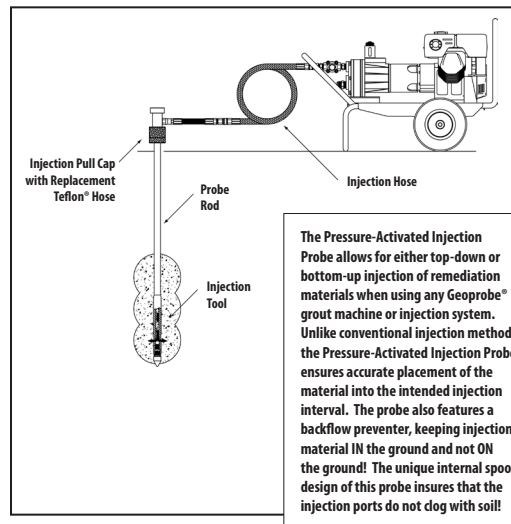

**The Pressure-Activated Injection Probe** allows for either top-down or bottom-up injection of remediation materials when using any Geoprobe® grout machine or injection system. Unlike conventional injection methods, the Pressure-Activated Injection Probe ensures accurate placement of the material into the intended injection interval. The probe also features a backflow preventer, keeping injection material IN the ground and not ON the ground! The unique internal spool design of this probe insures that the injection ports do not clog with soil!



1-800-436-7762 • www.geoprobe.com