

Manual Slide Hammer

Operation Instructions

Instructional Bulletin No. 17743

PREPARED: February, 2001



! WARNING !

Think Safety!!

1. Read all instructions before operating the manual slide hammer.
2. Never operate the slide hammer without a loop pull cap on top of the guide rod.
3. Always grasp the slide hammer handles with both hands while driving tools.
4. Check underground utilities before driving tools into the subsurface.

Instructions for Operating the Geoprobe® Manual Slide Hammer System

1.0 Objective

The Geoprobe® Manual Slide Hammer System enables the operator to advance sampling tools into the subsurface without the aid of power equipment. A weighted slide hammer is physically lifted and lowered along a guide rod to drive the attached tool string into the ground.

While the slide hammer system has been designed with the utmost concern for safety, it is ultimately the responsibility of the operator to use this equipment in a safe and sensible manner. This document identifies the components of the Geoprobe Manual Slide Hammer System and presents specific techniques for their safe operation.

2.0 Available Equipment

The manual slide hammer system can utilize a 15-, 30-, or 45- pound hammer and either 1.0- or 1.25-inch diameter probe rods. Basic tools include a slide hammer, slide hammer anvil, loop pull cap, and probe rods. Part numbers for these required items as well as other optional tools are listed below. Refer also to Figure 1.

Slide Hammer, 45 lb. (16153)

Slide Hammer, 30 lb. (16151)

Slide Hammer, 15 lb. (16446)

1.25 Slide Hammer Anvil Kit (17691)

includes: (1) Slide Hammer Anvil, for 1.25-in. probe rods (16175)

(1) Loop Pull Cap, for 1.25-in. probe rods (AT1221)

1.0 Slide Hammer Anvil Kit (17690)

includes: (1) Slide Hammer Anvil, for 1.0-in. probe rods (16155)

(1) Loop Pull Cap, for 1.0-in. probe rods (AT124B)

Slotted Cap, 1.0 in. to 1.0 in. (16447)

Probe Rod, 1.25 in. OD, 36 in. or 48 in. length (AT1236 or AT1248)

Probe Rod, 1.0 in. OD, 36 in. or 48 in. length (AT10B or AT104B)

Slide Hammer Stabilizer, for 1.25-in. probe rods (16184)

Slide Hammer Stabilizer, for 1.0-in. probe rods (16165)

Probe Rod Jack, for 1.25-in. probe rods (AT9925)

Probe Rod Jack, for 1.0-in. probe rods (AT99)

Probe Rod Jack Adapter Kit, for 1.25-in. probe rods (15712)

3.0 Driving Rods

Tools can be advanced into the subsurface by lifting the slide hammer (Figure 2) and then quickly lowering it along the top probe rod. This section describes the procedure to safely drive tools using the manual slide hammer system. Operators may choose to utilize 1.0- or 1.25-inch probe rods in lengths of 36 or 48 inches. Refer to Figures 1 and 3 for identification of the parts specified in this section.

Note: Always wear appropriate safety equipment including a hard hat, eye protection, leather gloves, and steel-toe boots when operating the slide hammer system.

Note: Check underground utilities before driving tools into the subsurface.

1. Thread a slide hammer anvil onto the drive head of the sampler of your choice. (A 24-inch probe rod should be placed between the anvil and drive head when using a sampler shorter than 48 inches.)
2. Attach a probe rod to the slide hammer anvil. When fully assembled, the slide hammer will travel up and down this “guide rod” during the driving process. The same guide rod is used for driving as additional probe rods are added between the anvil and sampler only.

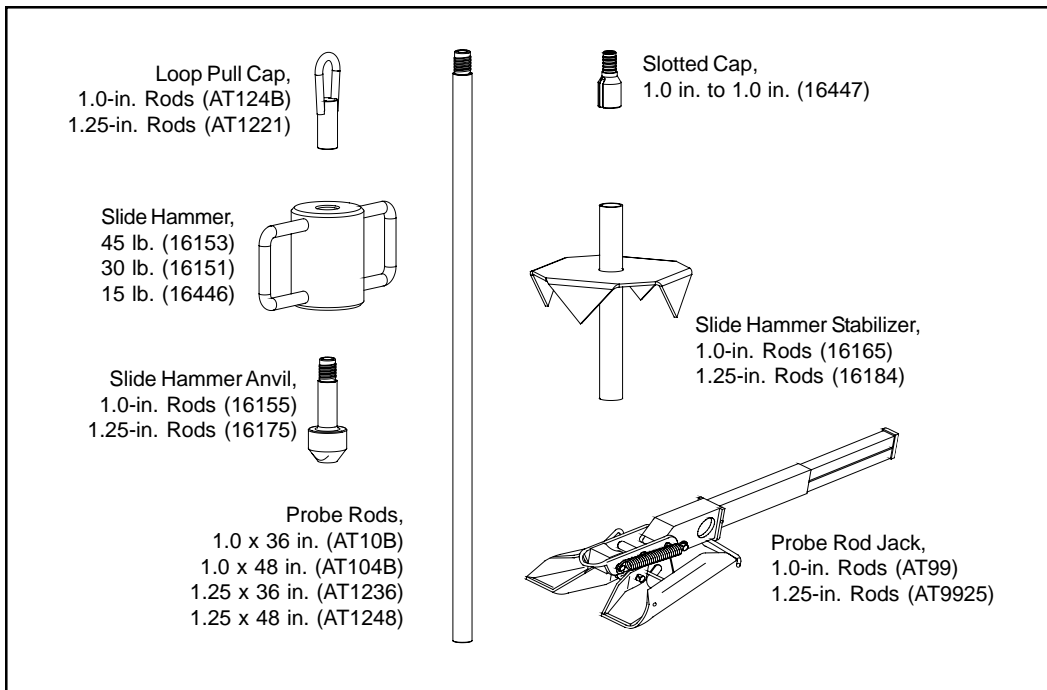

Figure 1. Components of the Manual Slide Hammer System.



Figure 2. With the tool string aligned for driving, lift the slide hammer to a comfortable height (as shown) and then quickly lower the hammer until it strikes the anvil. Maintain a constant hold on the hammer handles while driving.

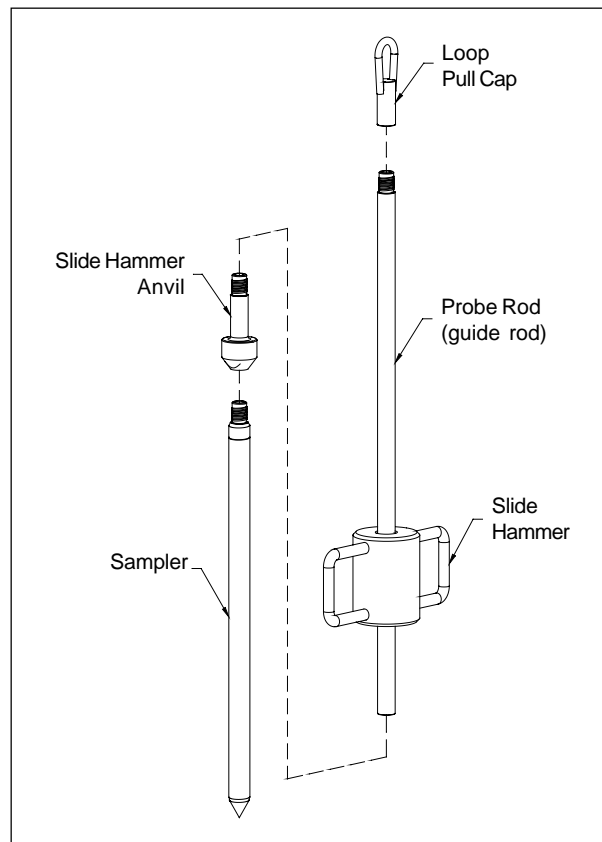

Figure 3. Assembly view of slide hammer system. Remember, you must use a loop pull cap at the top of the guide rod in order to safely trap the slide hammer.

3. Place the slide hammer on its side on the ground. Insert the guide rod/sampler assembly through the hole in the middle of the slide hammer.
4. Thread a loop pull cap onto the top of the guide rod.

! WARNING !

To avoid personal injury, never operate the slide hammer without a loop pull cap on top of the guide rod.

5. Raise the tool string into the vertical position being careful not to place your hands between the slide hammer and anvil. Maneuver the tools to the desired sampling location.
6. You are now ready to begin driving the tool string. Firmly grasp both slide hammer handles. Lift the slide hammer to a comfortable height and then quickly lower the hammer until it strikes the anvil. Continue cycling the slide hammer up-and-down taking care to keep the tool string properly aligned with the ground surface.

! WARNING !

To avoid personal injury, always grasp the slide hammer handles with both hands while driving tools.

7. Add a probe rod to the tool string when the slide hammer anvil is just above the ground surface. Begin by unthreading the guide rod from the anvil. Lift the slide hammer from the anvil and place it on the ground. Remove the anvil, thread another probe rod onto the tool string, and attach the anvil to the newly added probe rod. Lift the slide hammer back onto the anvil and replace the guide rod. Remember to utilize the loop pull cap.

Continue driving the tool string and adding probe rods until the desired depth is reached.

4.0 Retrieving Rods

The tool string is retrieved using the probe rod jack shown in Figure 1. With the slide hammer and anvil removed, slide the probe rod jack over the tool string and place it on the ground. Insert the jack handle into the rectangular housing. Actuate the jack handle up and down to pull the rod string from the ground.

5.0 Think Safety

You will be sliding a 15- to 45-lb. weight over your head! Heed the safety warnings of this document!



Corporate Headquarters

601 N. Broadway • Salina, Kansas 67401
1-800-GEOPROBE (1-800-436-7762) • Fax (785) 825-2097

COPYRIGHT© 2001 by Kejr, Inc.
ALL RIGHTS RESERVED

No part of this publication may be reproduced or transmitted in any form or by any means, electronic or mechanical, including photocopy, recording, or any information storage and retrieval system, without permission in writing from Kejr, Inc.

Geoprobe® and Geoprobe Systems®
are Registered Trademarks of Kejr, Inc., Salina, Kansas